

Fast Frequency Control in Multi-Terminal DC Networks

B.O. OJWANG, P.M. MUSAU, B. GATHUITA

Department of Electrical and Information Engineering,
University of Nairobi, UoN
Nairobi, Kenya
boazbenson@gmail.com

Abstract—This paper analyzed the frequency support characteristics of multiterminal direct current (MTDC) networks based on voltage source converter technology using the active power transferred from wind farm turbines and other ac systems as recovery power. A control scheme for Multi-Terminal – High Voltage Direct Current (MT-HVDC) to allow redistribution of active power, based on the idea of “power balance” is proposed. The goal of the paper was to ensure frequency deviations to be very minimal and to maintain the frequency around its rated value under normal conditions in the Multiterminal DC section. The control scheme uses droop controllers that were designed through formulation, in order to transfer the recovery power from wind farms to the main grid system which prevented a formation of frequency dips in the AC grid terminals and the entire MTDC system.

Index Terms-- fast frequency control, frequency support, inertia constant, multiterminal networks, rate-of-change-of-frequency

I. INTRODUCTION

A. Multiterminal DC Networks Definition

In this paper, MTDC networks (Multi-terminal DC) are taken into consideration as an up to date bigger solution to the HVDC scheme (high voltage direct current). MTDC control is concentrated on the regulation of asynchronous frequency and DC voltage. The study on the distinct transmission systems for fast frequency control has been held out previously in wind energy plants linked to Voltage Source Converters – High Voltage Direct Current (VSC – HVDC) systems [1-4]. With these schemes, it would be essential to have big interconnections between distinct locations as well as distinct synchronous regions in order to share the generation of renewable energy with other technologies. The overall frequency control performance of the entire Multiterminal DC -HVDC network is typically reduced by a combination of both generation Wind Farms (WFs) and conventional systems. This is because they have low inertia response relative to other generation systems. A coordinated control scheme is developed to prevent high frequency deviations on disturbed AC grids during wind turbine recovery period and also allow correct operation of wind turbine frequency response during multiple power imbalances. The proposed scheme gives priority to the frequency versus power drop of dual controllers and deactivates

the direct voltage droop during fast frequency response from MTDC systems, in order to eliminate interactions between the two droops. A 3-terminal HVDC system modeled using MATLAB which was used to demonstrate the effectiveness of the proposed control scheme and the results of both AC and DC side are compared.

B. Contribution

In this paper, we suggest using the derivative frequency detected by the grid system to use control loops to provide synthetic inertia response. In addition, we are introducing new control systems for dc voltage in the interconnecting converters inspired by the controller proposed in [9]. We further suggest a combined frequency and voltage controller scheme that regulates the frequency and high offshore voltages of DC grid to specified nominal values, which will be resulting in stable power distribution. The suggested model focuses on the converter's ac-side or onshore side, which answers the question of how to assess the capabilities of the fast frequency support system as well as alternatives to control architecture challenges. The other line is aimed at the converter's DC and offshore wind farm side. This is achieved through formulation of the droop controllers. The use of various droop controllers was considered by choosing and calculating the gains. Their respective gains were dependent on the DC voltage droop information of all the onshore converters.

II. LITERATURE REVIEW

Research has been undertaken over the past decade to define power schemes for synthetic inertia allocation and controlling of primary frequencies for both MTDC systems and linked wind energy plants.

As claimed by R. Li, S. Boshko, G. Asher with their work on, [16], the frequency reserves control requirement in a single AC schemes may be reduced by connecting multiple AC grid equipment via a Multiterminal DC scheme. They look at the design of a High Voltage Direct Current (HVDC) line converter for the system frequency control synchronous grid of offshore WFs. However, its limitation was that its articulation was simplified too much as it overlooked the switching reactance of the converter and represented a DC source on the inverter side. The interaction between different control loops for the AC-grids, doubly-fed induction generator (DFIG) Wind Farm (WF) and Line-commutated converters (LCC) to VSC-HVDC including the phase locked loops (PLL's) needs to be analyzed in the frequency-domain to characterize the frequencies of such systems which is one of the subject matters in this paper. In

[10], distributed Multiterminal DC secondary voltage controllers that do not depend on a slack bus are suggested. There is a review of the Voltage Droop Method (VDM) and three distributed Multiterminal-HVDC transmission system controllers are suggested. However, the analytic work in the reference mentioned are limited to Multiterminal DC system dynamics, thereby, any linked AC systems dynamics are neglected. Voltage Droop Method posed some major issues, however. Firstly, the bus voltages usually do not coincide to a value below or above the rated voltages. Secondly, the injected regulated currents do not correspond to the best value in this paper whereas the independence of AC and DC parties is not changed. In 2014 Taylor and Scardovi, suggested that the AC-systems linked by derived High Voltage Direct Current systems would be optimally decentralized [18]. They demonstrate that architecture for posset-causal DC segmented energy systems make them suitable for strong decentralized control methods that can decrease the communication requirements of their systems significantly. In particular, only communication between the AC subsystems directly linked to a DC line can achieve the ideal decentralized control. The control system is validated by simulation and its performance nearly as well as the centralized control system. This analysis ignores the HVDC voltage dynamics. The three primary fast frequency control systems (e.g. f-P droop, f-Vdc-Q droop, and dual f-P and f-Vdc-Q droop) are fitted and tested with all on-shore VSCs from the MTDC network. A centralized controller is suggested on the basis of a communicating network in [13]. It presents a developed version of the controller suggested in [15]. The improved controller scheme is capable of eliminating the variance in the frequency of the zones by including the integral term of the local frequency variation. However, the shifts in their dc voltages made the converters voltage to either rise or decrease in a high rate. This caused power imbalances. Furthermore, every controller's execution is desired to evaluate quantifications of voltages in all extra terminals of the DC side. In this paper we ensure that the change in frequency is at a high range so that the frequency control is of high degree hence ensuring the network is at equilibrium point.

III. PROBLEM FORMULATION

When a Voltage source converter-Multiterminal DC system is connected with a (Renewable Energy Systems) RES there is too much degrading of frequency hence resulting to low inertia emulation or provision. This means that there is low mechanical energy to handle the incoming load, Multiterminal DC. This results to a power imbalance due to this disturbance. To solve this, the stored kinetic energy from the turbines is released to try and achieve a power balance that would support the Multiterminal DC and AC systems.

Due to this there are low levels of Rate of Change of Frequency (ROCOF) df/dt which is given with the following equation, [19].

$$ROCOF = \frac{df}{dt} = \frac{\Delta P}{2H} \quad (1)$$

$$\Delta P = 2H \frac{df}{dt} \quad (2)$$

The H is termed as the inertial constant which is normally formulated as follows

$$H = \frac{\frac{1}{2}J\omega^2}{s_r} \quad (3)$$

The reactive power relates with the dc voltages while the active power relates with the frequency. The equations below describe this in depth [20]

$$f_s = f_0 + k_{pf}(P_{av} - P_s) \quad (4)$$

$$V_{dc} = V_{dc1} + k_{qv}(P_{av} - P_s) \quad (5)$$

$$k_p = \frac{\Delta f}{P_{max}} \quad \text{and} \quad k_q = \frac{\Delta V_{dc}}{Q} \quad (6)$$

The system operates with a Power to Voltage (P – V) droop controller during normal conditions and changes to a frequency to dc voltage during frequency disturbances. This relation is denoted by the following equation [17]

$$V_{dc}^* = V_{dc} - k_{pv}(P_{av1} - P_{av2}) + k_f(\Delta f_0) \quad (7)$$

At normal conditions the frequency deviations are equal to zero and the power from the Wind-side Voltage Source Converter (WVSC) is dispatched to the AC grids while the dc voltage is ensured to be stable in the Multiterminal DC system.

The new control approach will be as follows [17]

$$V_{dc}^* = V_{dc,i} - k_{pv,i}(P_{dc1,i} - P_{dc2,i}) \quad \forall i \in N_{cn} \quad (8)$$

$$V_{dc}^* = V_{dc,j} + k_{f,j}(f_{nom,j} - f_{s,j}) \quad \forall j \in N_{cg} \quad (9)$$

To implement it we fit a frequency and Power droop controller in Grid-side Voltage Source Converter (GVSC) and a DC voltage and Frequency droop controller in the Wind-side Voltage Source Converter.

$$P_{av}^* = P_{av1} - k_{vp}(V_{dc1} - V_{dc2}) + k_f'(\Delta f_0) \quad (10)$$

This method is prone to several limitations hence the need to improve it in order to provide fast frequency control. These demerits are due to the recovery power required by wind turbines after Synthetic Inertia Response (SIR). On the other hand, frequency deviation once it's gone beyond the limit margin the Grid-side Voltage Source Converter do switch to the frequency and power droop control where in this case the k_{vp} is equal to zero for it be able to control the referenced active power flowing into the Grid-side Voltage Source Converter. Thus, the new approach for control now becomes [20]

$$P_{av,i}^* = P_{av1,i} - k_{vp,i}(V_{dc1,i} - V_{dc2,i}) \quad \forall i \in N_{cn} \quad (11)$$

$$P_{av,j}^* = P_{av1,j} + k_{f,j}'(f_{nom,j} - f_{s,j}) \quad \forall j \in N_{cg} \quad (12)$$

It is assumed that no power losses encounter in the DC grid and also no power outages in the converter stations, as also the SIR is held inactive. With these conditions then we can be able to get linearity between the voltage deviations and the frequency deviations.

$$\Delta V_{dc} = \frac{\sum_{i=1}^{N_{cd}} k_{f,i}' \Delta f_{o,i}}{\sum_{i=1}^{N_{cn}} k_{vp,i}} \quad (13)$$

The DC voltage deviation can be calculated from the sum of exchanged power between converters in small-signal form:

$$\sum_{i=1}^N \Delta P_i = \Delta P_{losses} \quad (14)$$

The F-P droop method controls the supplementary active power, P_{n0} , transmitted to the main grid-side via GVSC1, if k_{vp1} is 0 below. In the case of the Multiterminal DC system having a balanced power flow then:

$$\sum \Delta P = \sum_{i=1}^N k_{vp,i} \Delta V_{dc,i} + \sum_{j=1}^l k_{fp,j} \Delta f_j \quad (15)$$

IV. PROPOSED METHOD

A. Research Design

Our research design was focused on the application of realist theory of frequency support in Multiterminal DC networks normally based on DC voltage manipulation.

The design procedure entails:

1. Firstly, provision of power and frequency is assessed. This part investigates how the wind turbines generates the speed

inertia response and hence power and frequency provision. Various frequency support methods are also researched in this section.

- Secondly, control mechanisms are formulated which are formulated briefly in the previous chapter. From the system design in the first part, a formulation is done on how to control the VSCs, specifically the Wind-side Voltage Source Converter and the Grid-side Voltage Source Converters. More-so a control mechanism is also investigated for the whole Multiterminal DC network.
- Given an analysis for both the DC and the AC grids are conducted to assess the network voltage, current and system's power using an optimized power distribution algorithm.

The coming up of the proposed system design configuration was the last thing. - The main configuration of the Multiterminal DC scheme, which is used as the basis for the analysis of the performance of the control strategy, is developed here. In this case, it's the independent wind farms supply power through converters to a DC network ring.

B. Optimization of VSC controller current and gain in the model.

The heuristic algorithm of Particle Swarm Optimization (PSO) was used for the optimization of each VSC controller in this model. In a PSO system, it is composed of a swarm of individuals (termed as particles) which fly to a search space. Every individual particle is a suitable solution for the problem being optimized. The particle's position is obtained through its best position that it has ever visited and the best position of the neighboring particle. If the whole swarm is the neighborhood of a particle, the best position in that neighboring area is called the global best particle and therefore the algorithm resulting to this scenario is called the global best PSO. The algorithm is typically a local or regional PSO if smaller neighborhoods are used. The performance of each individual particle, in other words, the closeness of the particle to the global-optimal, is determined by a fitness function which depends on the optimization problem. Particle swarm is based on the experience acquired by the individual particle and the neighboring particles, and their location is tuned into a multi-dimensional space for searching. Having noted that, the best individual position of the i^{th} particle is selected to be the best position visited by i^{th} individual so far (it results from the best fitness value).

TABLE 1: MAPPING SUMMARY OF PSO PARAMETERS

PSO Parameter Used	Initial Meaning	MTDC Relation
C1 and C2	Particle's constants of acceleration	Nominal or Rated Voltages and Frequencies
p	Period taken for particles to merge	Sample Control times of both frequency and voltage
N	Population size number of the particles in the swarm	No of terminals Referenced by the converters
$y_i(p)$	Pbest for i , i.e particle i best position	Least frequency deviations
$y_j^*(p)$	Gbest for i , i.e particle I global best position	Highest frequency deviations
$r1_j$ and $r2_j$	random coefficients affecting velocity	controller gain coefficients affecting the frequency deviations

C. Optimizing the VSC loop controllers

The input signal is implemented only in the d-axis current loop because the Inner Current Controller (ICC) Proportional Integral (PI) controllers are similar for both d and q-axis thus, a zero input is considered for q-axis.

$$I_{ICCmin} = \int_0^T t(i_d - i_{dref})dt \quad (16)$$

Once the Inner Current Controller has been tuned appropriately, the outer controllers are then optimized. In the Voltage source converter Control System, the tuned Current Controller is used and the PSO optimizes then the outer control loop. In this problem, optimization is performed using the objective function denoted below,

$$I_{IOCmin} = \int_0^T t(P - P_{ref})dt \quad (17)$$

D Proposed Model Design

The results obtained are based on a coordinated scheme that uses various droop configurations with specific gains to enhance a fast frequency response. These Droop control configurations are fitted in every converter in the Multiterminal DC network with each and every having its function to the whole system. Two modes are investigated which include, when the system is under normal operation and when it is affected by frequency disturbance caused by the power imbalances. The different droop control methods for the converters of the 3-Terminal voltage source converter network are shown in Figure 1. The Grid-side Voltage Source Converter (GVSC2) uses a P-vs-Vdc droop controller during normal operation and the GVSC1 uses V_{dc}-P drop in normal conditions in order to provide a balanced power distribution in the onshore side and DC grids. AC voltage is generated by the Wind-side Voltage Source Converter which uses the Voltage to Frequency (V-F) droop in the offshore grid. In the main grid converter station, the F - P droop was modeled to allow the distribution of additional recovered power from wind turbines to other system. The GVSC1 detects a deviation of the frequency during a frequency disruption and switches from the Voltage to Power (V- P) droop to a Frequency to Power (F - P) droop if the deviation obtained goes above 20 MHz = 0.02 Hz. The GVSC1 shown in Figure 1 was the main controller of frequency and active power in the whole network. It was designed by using the equation of V- P droop controller which is given by equation (18)

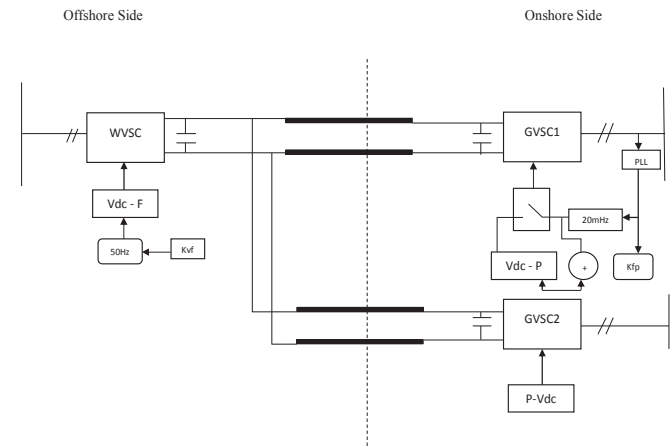

Figure 1. Droop Controls Linked to the proposed 3 Terminal high voltage direct current-based Model

$$P_n = P_{n0} - k_{vp,1}(V_{dc0} - V_{dc}) + k_{fp,1}\Delta f_1 \quad (18)$$

where $k_{vp1} = 1/k_{pv1}$ represents the gain coefficient of the voltage vs active power droop controller (V - P), and $k_{fp1} = k_{fv1} / k_{pv1}$ represents gain coefficient of the reference frequency vs active power droop control scheme (F vs. P). The Frequency to Power droop method, controls the supplementary active power, P_{n0} , transmitted to the main grid-side via GVSC1, if k_{vp1} is 0

V. RESULTS AND ANALYSIS

A. Frequency Dynamics of The Offshore side

The frequency dynamics of this part was determined through the formulation based on the Voltage vs Frequency droop controller. Due to the extra deviation in DC voltage produced from the wind turbine recovery power, the frequency deviation was increased during the time of 0s to 10s from 0.01 Hz to 0.03Hz. Once the wind power was recovered due to loading of the RES the deviations started to decrease or stabilize to near nominal values.

The wind farm inertia was controlled by the obtained offshore frequency. This would help to know the best amount of kinetic energy to be produced to offer stability of power in the grids.

TABLE 3: FREQUENCY RESULTS AT OFFSHORE SIDE

Nominal Frequency (Hz)	Timing (sec)	Frequency-Nadir (Hz)	Frequency Deviations (Hz)	Rocof Values
50.000	0	49.9890	-0.0110	0.0000
50.000	1	49.9877	-0.0123	0.0000
50.000	2	49.9870	-0.0130	0.0298
50.000	9	49.9698	-0.0302	0.0595
50.000	10	49.9690	-0.0310	0.0595
50.000	11	49.9704	-0.0296	0.0893
50.000	15	49.9824	-0.0176	0.0595
50.000	19	49.9900	-0.0100	0.0298
50.000	20	49.9900	-0.0100	0.0298

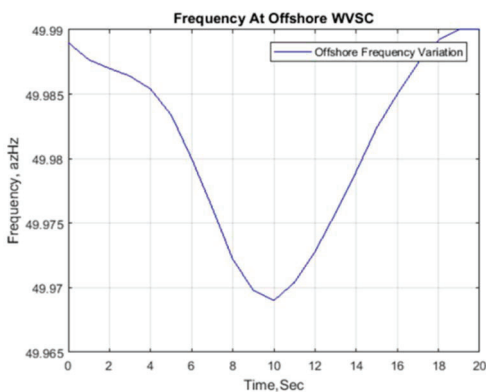

Figure 2. The Offshore Grid Frequency at WVSC

B. Frequency Dynamics at the Onshore Main grid

TABLE 4: FREQUENCY RESULTS AT ONSHORE SIDE

Frequency Deviations (Onshore)	Timing (sec)	Frequency Deviations (Offshore)	Resultant Deviations in the MTDC Grid
0	0	-0.0110	-0.0110
0.0017	1	-0.0123	-0.0106
0.0033	2	-0.0130	-0.0097
0.0223	9	-0.0302	-0.0079
0.0231	10	-0.0310	-0.0079
0.0219	11	-0.0296	-0.0077
0.0090	15	-0.0176	-0.0086
0.0001	19	-0.0100	-0.0099
0.0001	20	-0.0100	-0.0099

The system's frequency started to drop when there was a power generation loss at around 1s. During the sample time of 1s, the rate of change of frequency (RoCoF) was obtained at every sample time of 1s between a margin of 0.5s and was determined to be increasing as the frequency deviations increased. The maximum frequency deviation was measured at time 10 s as it had surpassed the maximum grid code frequency deviation of 0.02Hz thus making the GVSC1 to switch from Voltage vs Power to Frequency vs Power droop controller. Frequency of the onshore DC and AC side were computed by the formulae in the equation. The figure below shows the dynamics of frequency through the Grid-side Voltage Source Converter 1.

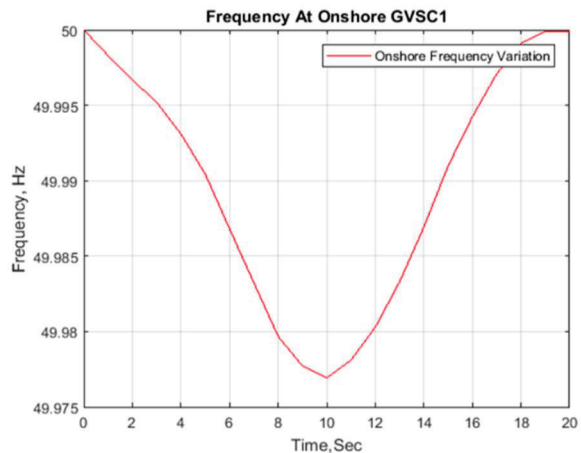

Figure 3: The Onshore Grid Frequency at GVSC1

C. Comparison of Frequency Deviations Between Offshore and Onshore DC side

Deviations of the offshore side were first observed to be negative caused by the configuration of the Voltage vs Frequency (V-F) droop scheme. The first drop triggered a steady change in the generated torque of the generator due to the wind farm inertia provision systems, which led to a reduction in the rotor speed to recover the kinetic energy that has been stored in the wind turbine rotation during the 1-9s cycles. After the active power is restored by addition of kinetic energy the deviations began to decrease. This effect is similar on the onshore side where power was distributed in the main grid and other AC system resulting to increase in frequency deviation levels in both the AC and DC grid. Following the characteristic effect of the F- P droop scheme the deviations did not rise to high values as observed in the offshore

side. A significant balance between the two dictates the frequency deviations in DC section itself.

TABLE 5: FREQUENCY DEVIATION RESULTS BETWEEN OFFSHORE AND ONSHORE

Nominal Frequency (Hz)	Timing (sec)	Frequency-Nadir (Hz)	Frequency Deviations (Hz) (f _{mom} -f _{nadir})	Rocof Values
50.000	0	50.0000	0	0
50.000	1	49.9983	0.0017	0.0506
50.000	2	49.9967	0.0033	0.0988
50.000	9	49.9777	0.0223	0.6629
50.000	10	49.9769	0.0231	0.6867
50.000	11	49.9781	0.0219	0.6516
50.000	15	49.9910	0.0090	0.2684
50.000	19	49.9999	0.0001	0.0030
50.000	20	49.9999	0.0001	0.0030

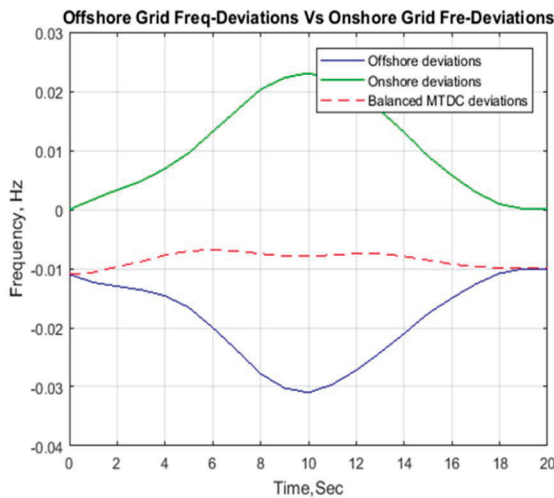

Figure 4: The Onshore and Offshore Frequency Deviations & Balanced MTDC

VI. CONCLUSION

Multiterminal DC systems which are voltage source converter based, is a new technology used to transmit generated power from offshore wind farms to land where there are various links to the electricity grids that supply power to different areas. This paper has investigated this ideology and how to enhance great efficiency of the system through fast frequency control. A droop control scheme has been implemented which caters for the recovery power produced at the wind turbines to other ac grids in the network. This has been done in order to bypass further decrease in the active power generated and the frequency in the AC and DC grids once there is an instant power generation loss. With the applied droop control scheme, the use of the frequency vs power droop controller in the VSC connected to the Main grid is of essence. This is because it allows additional active power to flow to the AC grid once a loss occurs as it monitors frequency not to go beyond margins above the rated frequency deviation of 0.02 mHz. It was generally noted that the allocation of active power at the receiving terminals successfully reduces the magnitude of the frequency nadirs produced on each terminal by sharing the power deficit burden during the event of several frequency disturbances.

VI. REFERENCES

- [1] I.D. Margaris, S.A. Papathanassiou, N.D. Hatzigiorgiouris, AD. Hansen, and P. Sorensen, "Frequency Control in Autonomous Power Systems with High Wind Power Penetration," *IEEE Transactions on Sustainable Energy*, vol. 3, no. 2, pp. 189-199, April 2012.
- [2] Jiebei Zhu, Campbell D. Booth, Grain P. Adam, Andrew J. Roscoe and Chris G. Bright, "Inertia Emulation Control Strategy for VSC-HVDC Transmission Systems," *Power Systems IEEE*, vol. 28, no. 2, May 2013.
- [3] Nilanjan Ray Chaudhuri, Rajat Majumder, and Balarko Chaudhuri, "System Frequency Support through Multi-Terminal DC (MTDC) Grids," *Power Systems IEEE*, vol. 28, no. 1, pp. 347-357, 2013
- [4] Gonzalez-Longatt, "Impact of synthetic inertia from wind power on the protection/control schemes of future power systems: Simulation study," *DPSP 2012. 11th International Conference on Developments in Power Systems Protection*, pp. 23-26, April 2012
- [5] Delille, G.; Francois, B.; Malarange, G., "Dynamic Frequency Control Support by Energy Storage to Reduce the Impact of Wind and Solar Generation on Isolated Power System's Inertia," *Sustainable Energy IEEE*, vol.3
- [6] ENTSO-E, Draft network code on high voltage direct current connection and DC-connected power park modules. 2014
- [7] Liang, J., Jing, T., Gomis-Bellmunt, O., Ekanayake, J., Jenkins, N... Operation and control of multiterminal HVDC transmission for offshore wind farms. *Power Delivery IEEE* 2011;26(4):2596-2604.
- [8] T. T. Gmbh, "Requirements for Offshore Grid Connections," *October 2010*.
- [9] T. Jouini et al., "Grid-Friendly Matching of Synchronous Machines by Tapping into the DC Storage," *IFAC-Papers Online*, vol. 49, issue 22, 2016, pp. 192-197
- [10] M. Andreasson, D. V. Dimarogonas, and K. H. Johansson. Distributed controllers for multi-terminal HVDC transmission systems. *arXiv preprint:1411.1864*, 2014.
- [11] M. Andreasson, R. Wiget, D. V. Dimarogonas, K. H. Johansson, and G. Andersson. Distributed primary frequency control through multi-terminal HVDC transmission systems. 2015.
- [12] de Courreges d'Ustou, B. (2012). Optimal Control Design for Multiterminal HVDC. Ph.D. thesis, University of Pittsburgh.
- [13] J. Dai and G. Damm. An improved control law using HVDC systems for frequency control. In *Power systems computation conference*, 2011.
- [14] J. Dai, Y. Phulpin, A. Sarlette, and D. Ernst. Impact of delays on a consensus-based primary frequency control scheme for AC systems connected by a multi-terminal HVDC grid. In *IEEE Bulk Power System Dynamics and Control*, pages 1-9, 2010.
- [15] J. Dai, Y. Phulpin, A. Sarlette, and D. Ernst. Voltage control in an HVDC system to share primary frequency reserves between nonsynchronous areas. In *Power systems computation conference*, 2011.
- [16] R. Li, S. Bozhko, and G. Asher. Frequency control design for offshore wind farm grid with LCC-HVDC link connection. *IEEE Transactions on Power Electronics*, 23(3):1085-1092, 2008.
- [17] B. Silva, C. L. Moreira, L. Seca, Y. Phulpin, and J. A. Peas Lopes. Provision of inertial and primary frequency control services using offshore multiterminal HVDC networks. *IEEE Transactions on Sustainable Energy*, 3(4):800-808, 2012.
- [18] J. A. Taylor and L. Scardovi. Decentralized control of DC segmented power systems.
- [19] Z. Qing-Chang and G. Weiss, "Synchronverters: Inverters That Mimic Synchronous Generators," *Industrial Electronics IEEE*, vol.58, pp. 1259-1267, 2011.
- [20] A. Perera, "Virtual Synchronous Machine-based Power Control in Active Rectifiers for Micro Grids," Master dissertation, *Norwegian University of Science and Technology*, 2012.